

# 147046

## Mini Market

Batch 220542

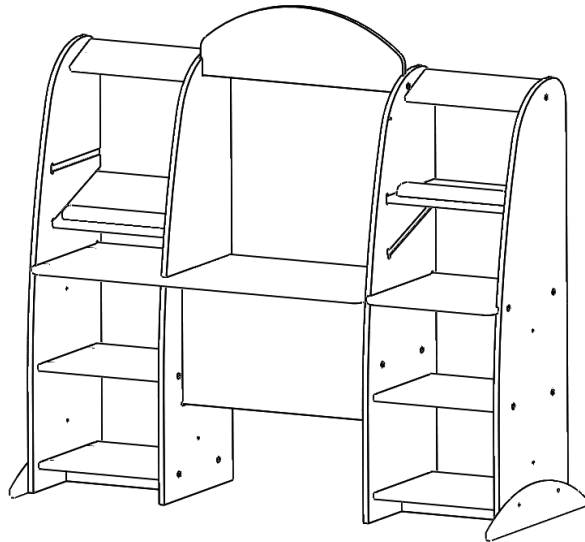

### **WARNING!**

#### **Adult Supervision Required**

This product is designed for young children and therefore supervision is required at all times.

#### **Must be assembled by adults**

Assembly by 2 adults is recommended

#### **Protect the finish when assembling**

We recommend assembling the product on a carpeted or equivalent surface to protect the finish.

#### **Indoor use on a level surface**

This product is designed for indoor use only and must be used on a level surface.

#### **Maintenance**

Please check the product at regular intervals, and frequently tighten fixings if necessary. If maintenance is not carried out, the product could cease to function properly. Periodically inspect for cracks, breaks, loose parts, missing parts, and/or malfunctions. Remove the product from service when any condition develops that might make operation unsafe.

#### **General Cleaning**

Clean the surface using a slightly damp cloth and if necessary a mild dish washing liquid. Too much water may harm the finish of the wooden parts. Do not use any cleaning product containing alcohol, bleach, ammonia or abrasives. These will dull any shiny surfaces on the product. We recommend that you test all cleaning materials on the underside of any surface that would not be seen during normal use of the product.

#### **Blackboard**

The blackboard board can be cleaned using a soft dry cloth or a slightly damp cloth.

#### **Whiteboard Cleaning**

Use a soft dry or damp cloth. If the ink has been left on for a long time, rub clean with a damp cloth and then use a cleaner recommended by the supplier of your whiteboard markers. Abrasive cleaning agents will damage the whiteboard surface.

#### **User Modifications**

We cannot be responsible for modifications made by customers to our products in the field without our supervision, testing, or evaluation.



Inspire · Create · Educate

**Please keep these instructions for future reference**

Findel Education Ltd, 2 Gregory Street, Hyde, Cheshire SK14 4TH | Tel: +44 (0) 161 367 2000



Made in Britain

## Bolt Pack

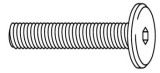

**2x**

30mm Brass Hex. Head Bolt (77)

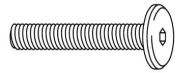

**30x**

35mm Brass Hex. Head Bolt (78)



**4x**

50mm Brass Hex. Head Bolt (80)

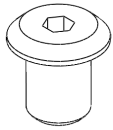

**2x**

M6 Brass Bolt Sleeve (No.105)

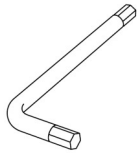

**1x**

5mm Allan Key (103)

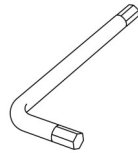

**1x**

4mm Allan Key (102)



**34x**

M6 x 12.5mm x 10mm C=7.5mm cross dowel (86)

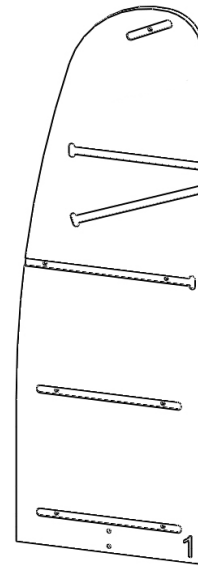

**1x**  
Side 1

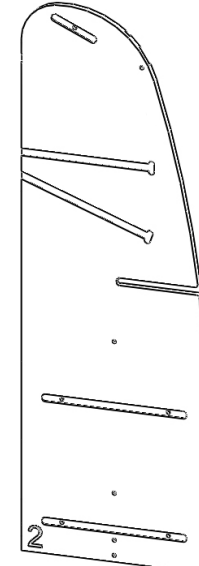

**1x**  
Side 2

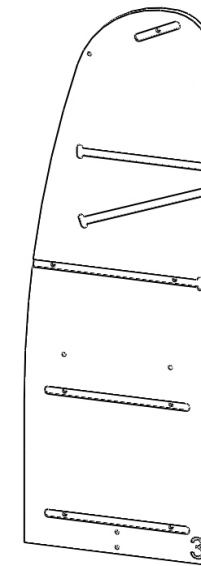

**1x**  
Side 3

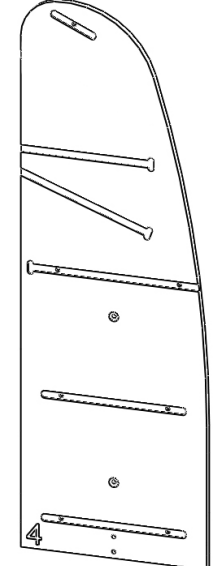

**1x**  
Side 4

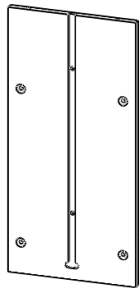

**1x**  
Small Side

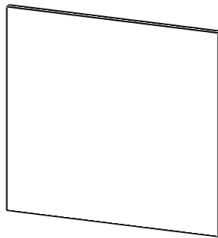

**1x**  
Blackboard

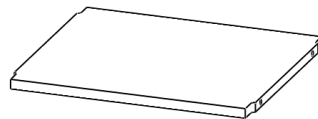

**4x**  
Fixed Shelf



**2x**  
Feet

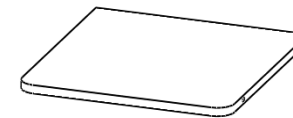

**1x**  
Small Counter Top

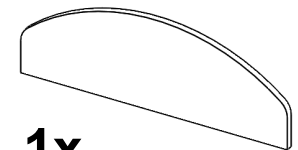

**1x**  
Drywipe board

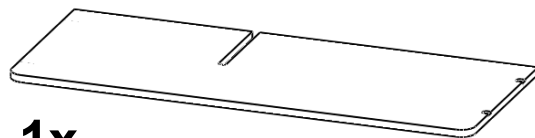

**1x**  
Large Counter Top

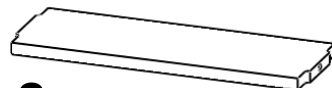

**2x**  
Roof



**2x**  
Slide Out Shelf Ledge

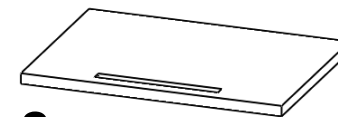

**2x**  
Slide Out Shelf



**2x**  
Kick Board

### 3 Configuration Options

**A**

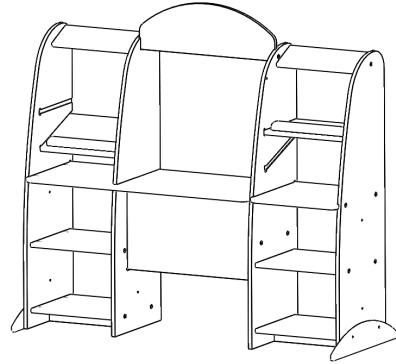

**B**

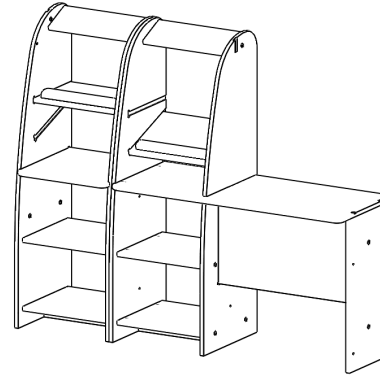

**C**

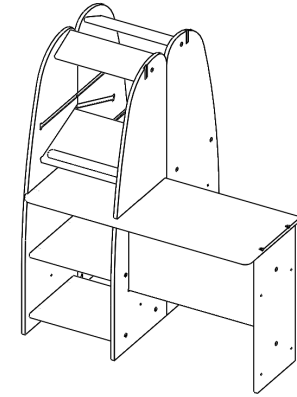

**1**

32x



No.86

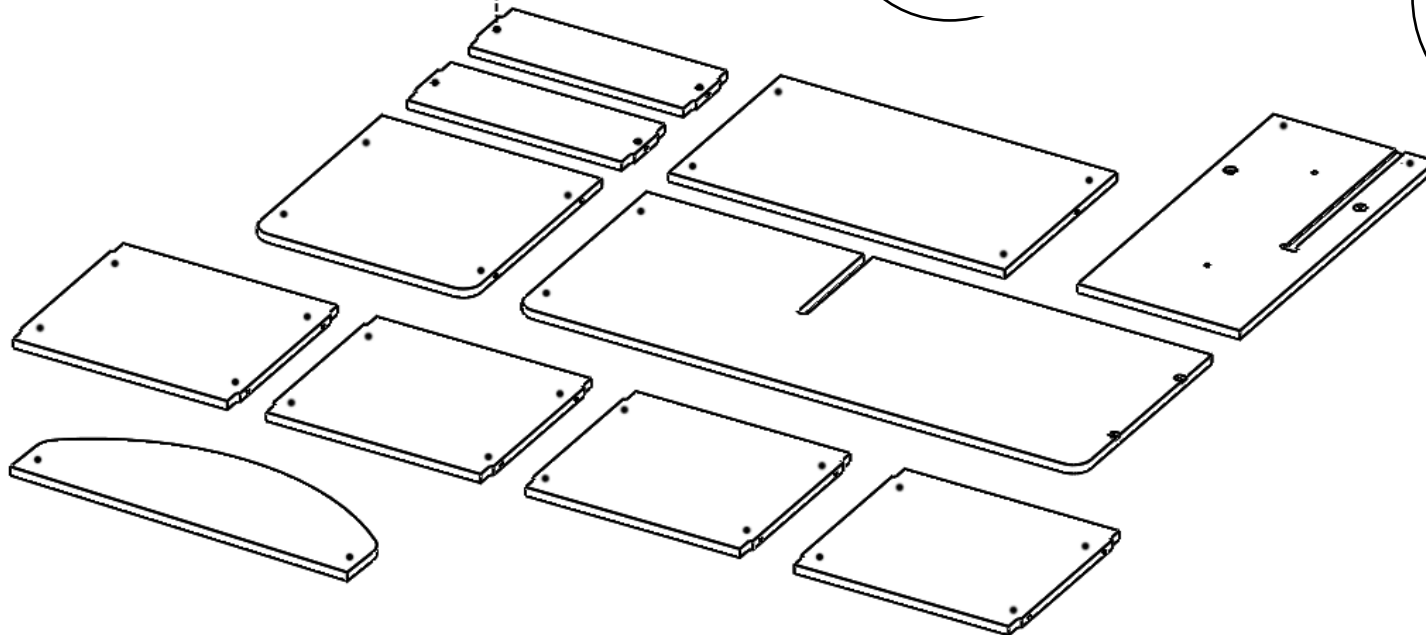
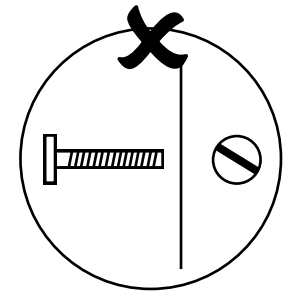
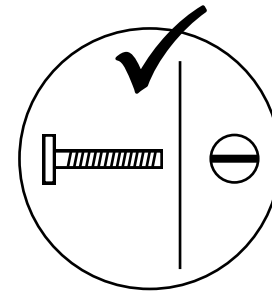

**2** **Configurations A, B & C**  
Secure these parts using  
5 x 35mm bolts

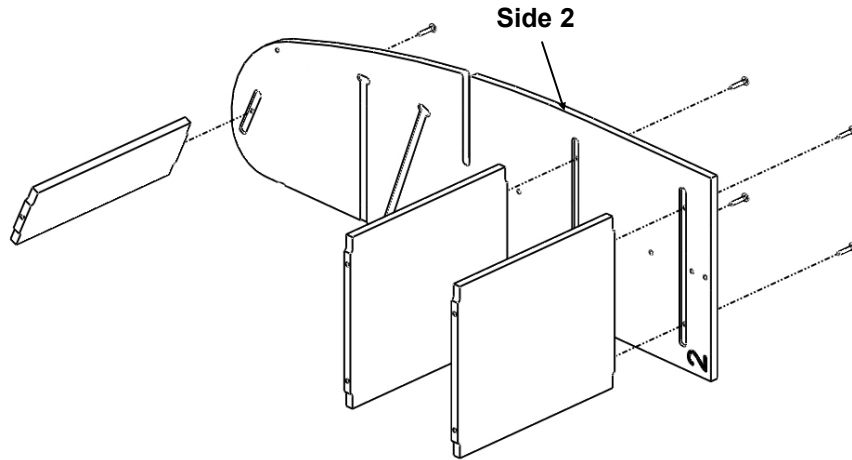

**3** **Configuration A**  
Use 2 x 50mm bolts to  
secure the feet and  
3 x 35mm bolts for the  
other parts.

**Configuration B & C**  
Do not assemble the  
feet in this step.  
Use 5 x 35mm bolts to  
secure Side 1 to the  
other parts.

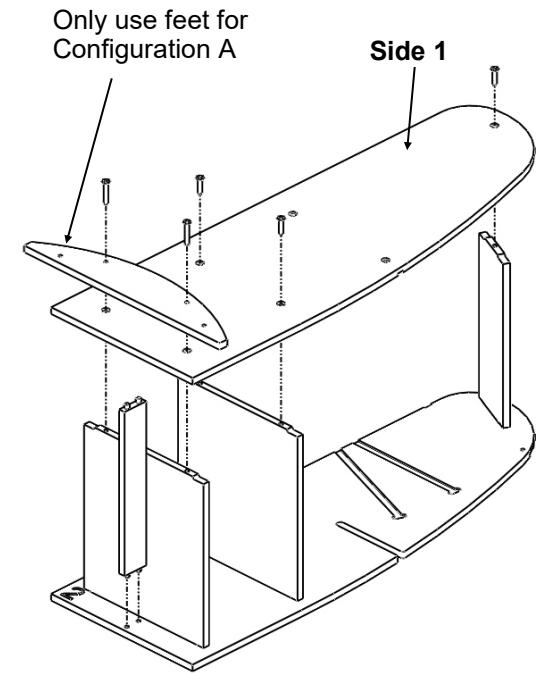

**4** Configurations A, B & C  
Secure the blackboard and small side using 4 x 35mm bolts

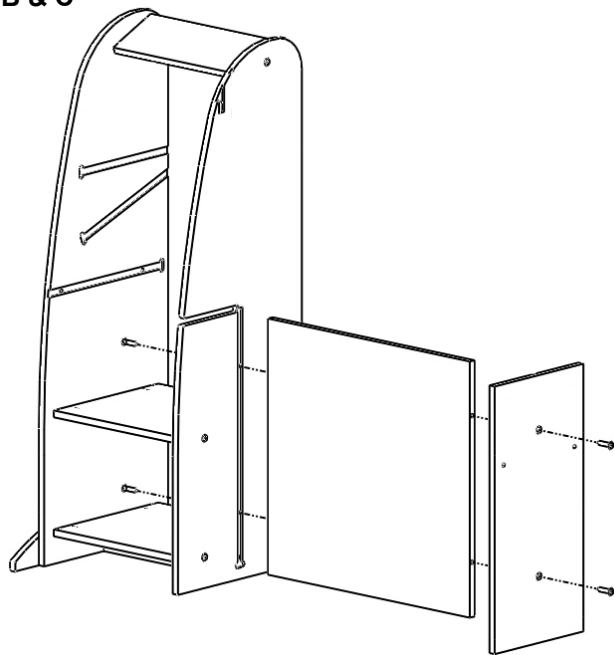

**5** Configurations A, B & C  
Use 4 x 35mm bolts after sliding the large counter top into place

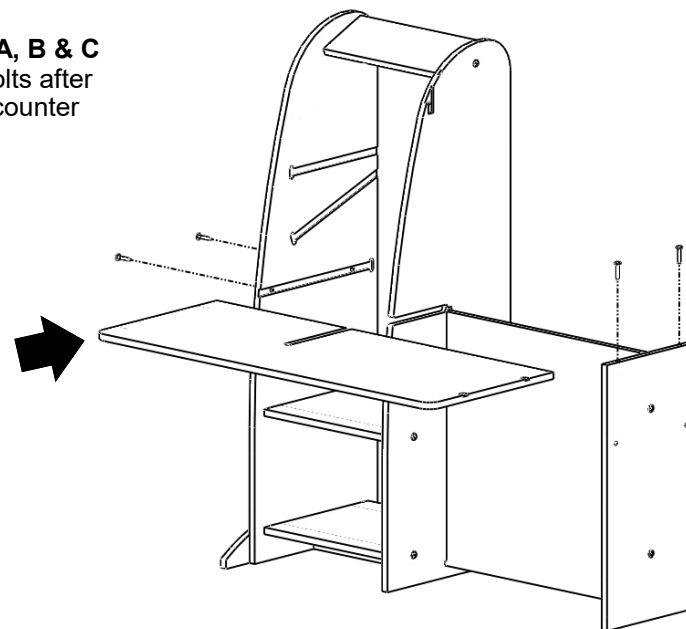

**6** Configurations A, B & C  
Secure these parts using 5 x 35mm bolts

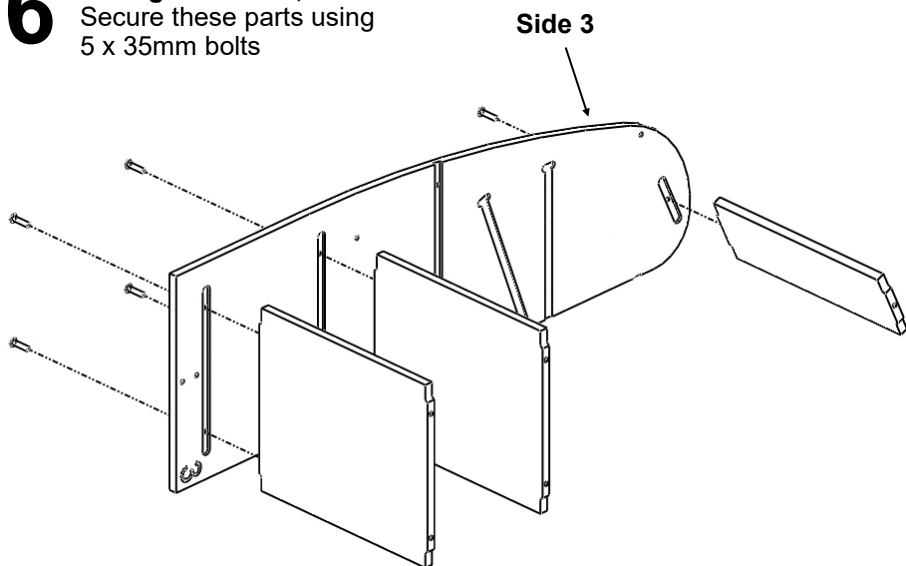

**7** Configuration A  
Use 2 x 50mm bolts to secure the feet and 3 x 35mm bolts for the other parts.

Configuration B & C  
Do not assemble the feet in this step.  
Use 5 x 35mm bolts to secure Side 4 to the other parts.

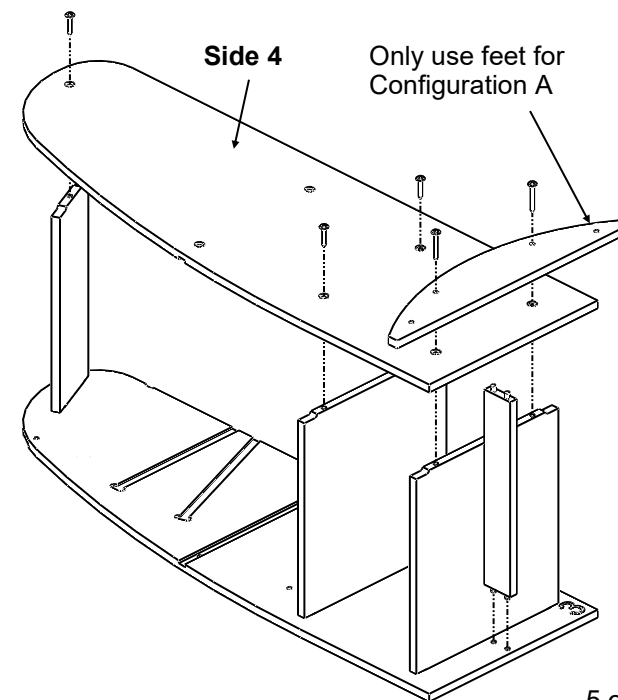

**8** Configurations A, B & C  
Slide the small counter top  
in place and secure using  
4 x 35mm bolts

Go to Step 9 for  
Configurations B & C

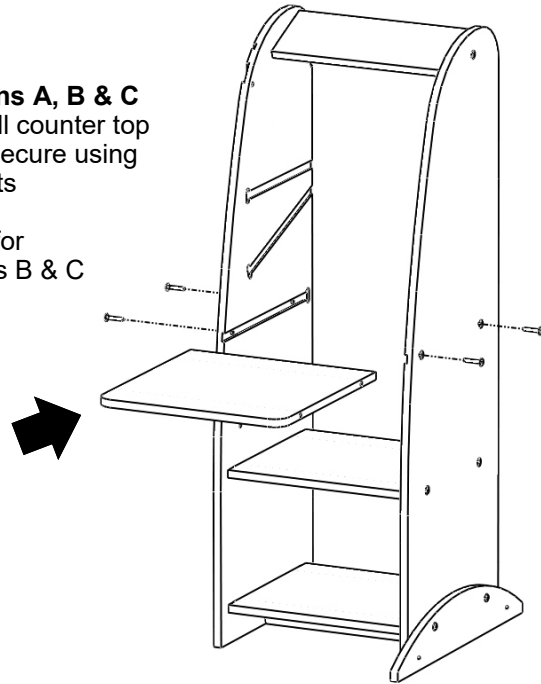

**9** Configuration A  
Secure the smaller  
unit to the larger unit  
using 2 x 30mm  
bolts

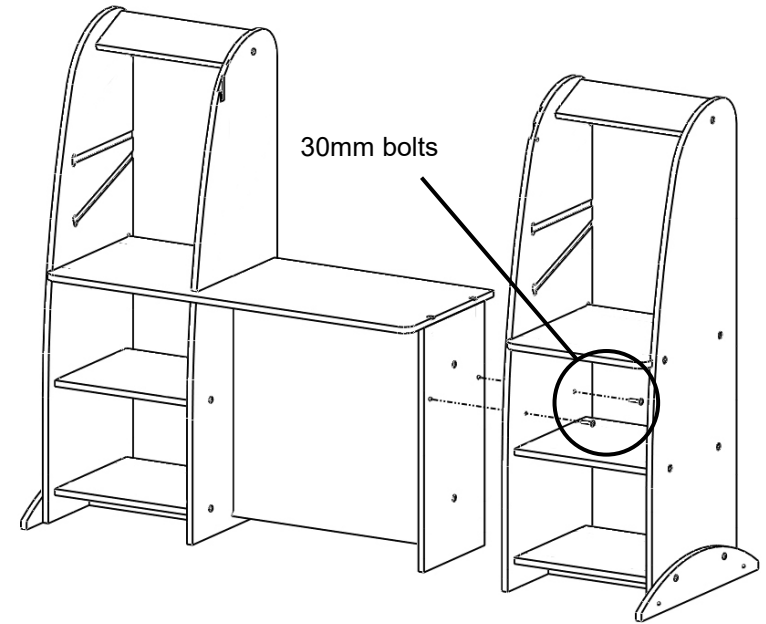

**10** Configurations A, B & C  
Go to step 11 for  
Configuration B

Go to Step 12 for  
Configuration C

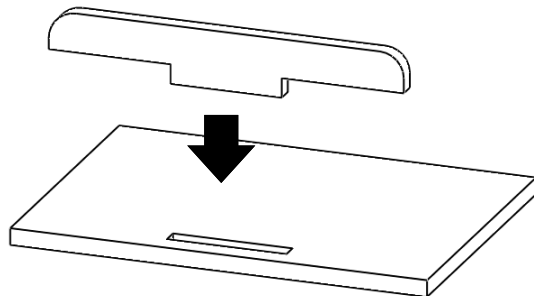

**11** Configuration A  
Secure the drywipe  
panel using 2 x  
35mm bolts.

Slide the 2 x  
removable shelves  
into position

**Configuration A  
is now complete**

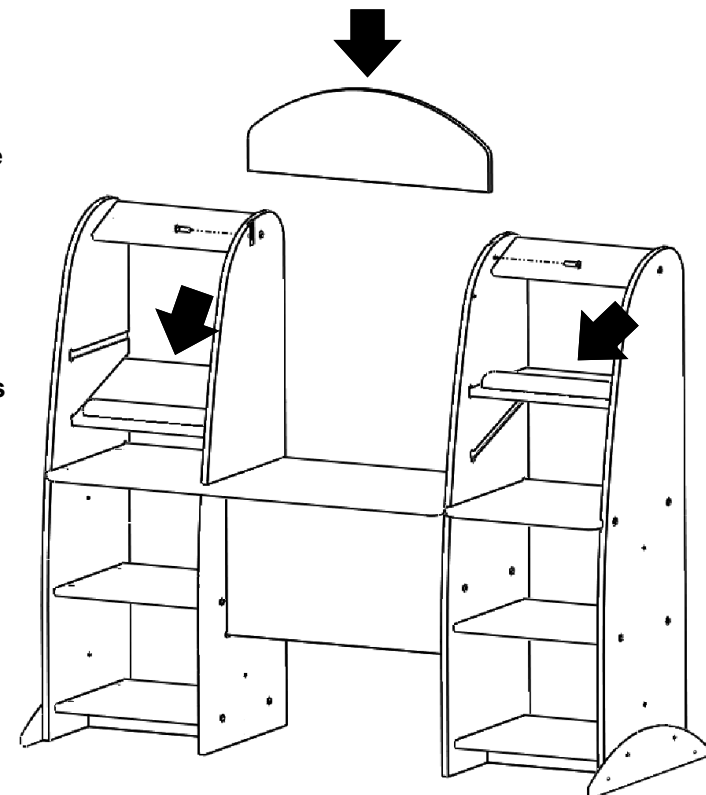

# 12

## Configuration B

Secure the 2 large sub-assemblies together using 2 x 30mm bolts and 2 x bolt sleeves.

Remove the 2 x 35mm bolts and attach the feet using 2 x 50mm bolts as shown.

Slide the 2 Sliding shelves into their slots

**Configuration B is now complete**

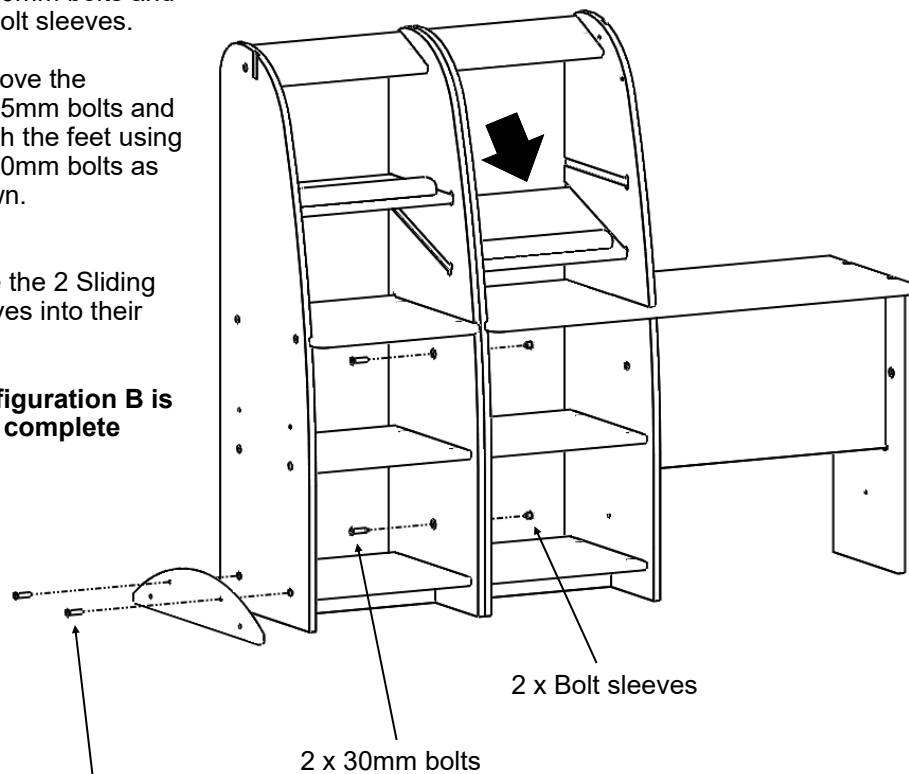

Remove the 2 x 35mm bolts and attach the feet using 2 x 50mm bolts

# 13

## Configuration C

Insert the 2 slide out shelves before positioning the 2 large sub-assemblies together.

Secure one of the feet using 2 x bolt sleeves and 2 x 30mm bolts as shown

**Configuration C is now complete**

