



**Harrod<sup>TM</sup>  
Sport**

*The original since 1954*

# Goal Post Safety

**General Operation & Maintenance  
Recommendations for Sports  
Ground Equipment**

# Goal Post Safety

General Operation & Maintenance Recommendations  
for Sports Ground Equipment



**It is the responsibility of the facility operator to provide equipment that is fit for purpose and maintained to the required standard. Operators also have a responsibility to staff under the Health & Safety at Work Act to ensure that staff are properly trained to carry out the required tasks for which they are employed. It is the facility providers who could find themselves liable in the case of any accidents where staff are found not to be competent.**

## Assembly & Dismantling

1. When erecting equipment always use the instructions and recommendations provided by the manufacturer.
2. We remind you that the appropriate personal protective equipment (PPE) must be worn at all times.  
e.g. Hard hat, steel toe-cap boots, gloves etc.
3. When tall and/or heavy equipment is being erected it is recommended that scaffolding and/or heavy lifting equipment is used. A risk assessment should be carried out if necessary.
4. The correct tools for the job must be used at all times.
5. Assembly must be carried out by a sufficient number of competent persons.

## Checking Equipment

Equipment should be checked on a regular basis. This requires positive action, and the information gathered must be recorded and acted upon immediately should any faults be found.

1. Check all equipment a minimum of once every week - but always before any game or training activity.
2. Carry out a thorough visual check of the whole goal. Check that all fixings are secure and there are no loose or missing nuts, bolts, pins or other fixings.
3. If nuts, bolts, pins or other fixings are loose or missing it is not possible to assemble the equipment correctly. It is therefore vital that missing parts are purchased from the manufacturer to ensure compatibility.
4. If parts of the goal are bent or other damage is present there may be more damage internally which is not visible and could result in the goal collapsing or tipping. The goal should be taken out of action and removed from site.
5. Check that all pivot points are in good condition and lubricated with grease.
6. Any chips or scratches must be treated to prevent corrosion occurring at these points.
7. Check all anchoring attachments and anchoring points.
8. Should weight-type anchors be used, check there are the correct number for the size of the goal.
9. If you find a fault - you must record the fault and not continue to use the goal. It must be correctly repaired or replaced with new equipment.
10. Do not modify goals by welding or by substituting with incorrect parts. If any part is missing or broken, obtain a replacement from the original manufacturer.
1. Wheel mechanisms should be complete and in full working order.
12. Inflatable tyres must be checked for punctures and be inflated to no more than maximum pressure marked on tyre.
13. Cellular or solid type wheels are the preferred option as little maintenance is required.

# Goal Post Safety

General Operation & Maintenance Recommendations  
for Sports Ground Equipment

## Checking Netting

1. Check for missing or broken net fixings as these may allow a ball to pass between the edge of the net and goal frame, resulting in confusion over whether or not a goal has been scored.
2. The size of the mesh of the net has been chosen to reduce the risk of injury caused by entrapment. If there are broken cords the holes become larger than intended and require repair or replacement.
3. Any broken cord in the nets may be able to be repaired using the same cord used to manufacture the net.
4. Nets must be stored out of direct sunlight and away from rodents.

***The Code Of Practice provided by BS 8461 gives guidance as to the type of check that should be carried out on football goals and how often they should be checked. Although this is football specific it is widely considered best practice for all sports.***

## Storage

1. Our recommendations regarding anchoring must still be adhered to when freestanding products are stored assembled.
2. If equipment has folding back supports it is recommended that the posts are stored flat on the ground. If they are required to be stored vertically, e.g. leant against a fence, they must be attached in such a way as to prevent them falling over.
3. When dismantled, parts must be stored safely & securely in order to prevent accidents in the storage area.

## Moving

1. Our recommendations regarding anchoring must still be adhered to when freestanding products are stored assembled.
2. If equipment has folding back supports it is recommended that the posts are stored flat on the ground. If they are required to be stored vertically, e.g. leant against a fence, they must be attached in such a way as to prevent them falling over.
3. When dismantled, parts must be stored safely & securely in order to prevent accidents in the storage area.
4. If additional weights are fitted to the goal, they must be removed first before attempting to move the goal. Once the goal is in position, carry the weights to the goal and re-attach.
5. Where goals with specific folding mechanisms are used, care must be taken to fold in accordance with both the instructions and labels. Damage can often occur when mechanisms are not released in the correct manner. Always refer to labels and instructions.
6. Fence folding style goals, with socketed support posts, are designed to be manoeuvred simultaneously by two competent persons. Care must be taken whilst moving the goal to ensure the net does not become entangled.
7. Goals fitted with wheels should be moved by using 4 competent persons in each corner of the frame and in the correct manner as stated in the assembly instructions.
8. In the case of integrally weighted goals, 4 competent persons must be used as per standard wheeled goals, it is important to check that the flip up wheel is locked in place before attempting to move the goal.

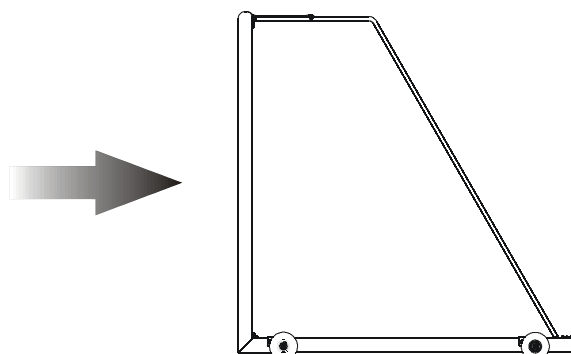

# Goal Post Safety

General Operation & Maintenance Recommendations for Sports Ground Equipment

## Keeping Records

1. The safety of equipment is the responsibility both of the facility providers (who should provide safe goals, installed and maintained in a safe condition) and of the users (who should only use the equipment for its intended purpose).
2. Facility providers should be aware of operation and maintenance guidelines and keep records of all checks, installations and maintenance carried out.

Goal Record Sheet				
Goal Reference <small>Field &amp; Month End</small>				
Date	Type of check	Findings	Action taken	Checked by
10th Dec 2012	Weekly	Scratched paint work on left hand upright.	Painted rear required area – used Harrod Sport white touch up paint.	
10th Dec 2012	Weekly	All ok.	None.	
2nd Jan 2011	Full	Good passed strength & stability test – see other guidelines.	Full Goal Post 2011 Assessment undertaken.	
10th Jan 2011	Weekly	Goal Net bar bolts and broken washers, some not kinetic seating.	Purchased new set and fitted to goal.	

Harrod UK Limited, Pinbush Rd, Lowestoft, Suffolk NR33 7NL • Tel: 01502 583515 • Email: sales@harrod.uk.com • www.harrod sport.com

## GUIDELINES FOR SPECIFIC SPORTS:

### Hockey

1. We strongly recommend that wheels are used to transport hockey goals, otherwise the goals should only be lifted with a minimum of four competent persons.
2. Only devices specified by the manufacturer must be used to manoeuvre goals.
3. Hockey Goals with rear fitted wheels must be tipped onto the wheels using four competent persons. There should be one person in each corner of the goal. The top rear support bars and side frames are integral parts of the goal for supporting the netting and are not to be used as the principle method for tipping the goal.
4. When using front flip-over type wheels, the lifting handles fitted to the goal are to be used when flipping the wheel into place. This requires two people per side (one to lift, one to flip).

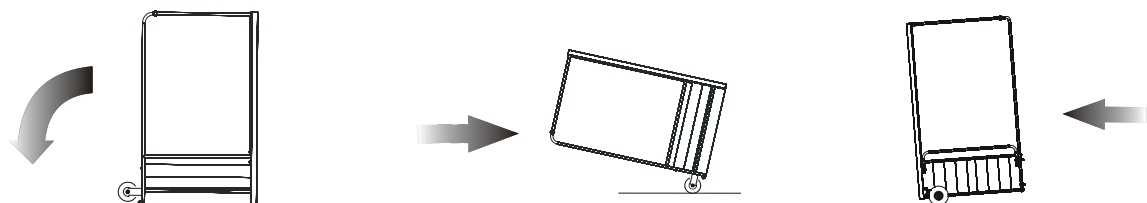

5. In the case of Integrally weighted, 4 competent persons are required to move the goal. Standing directly behind the goal. Put one foot on the axle bar to stabilise the goal and at the same time pull the goal back together until the goal is in the position. Manoeuvre the goal into the desired location and carefully let the goal down, making sure that the goal is not dropped.
6. Integrally weighted goals require a minimum pitch run off of 2 metres and must not be stored with the back of the goal against a surround fence or wall. To ensure the goal can be moved space must be available to allow the goal to be tipped up onto its roller.

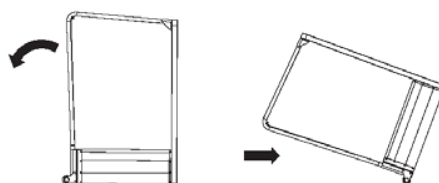

## GUIDELINES FOR SPECIFIC SPORTS (continued):

### Tennis

1. Freestanding Tennis Posts should only be moved by means of transporter trolleys, unless the posts have been completely dismantled.
2. A minimum of 2 transporter trolleys must be used per set of posts.
3. Posts should not be stored on trolleys at any time.
4. Only use trolleys that were specifically made for transporting tennis posts. Two competent persons are required to lift each end of posts onto the trolley. Use fixing bolts to secure posts on trolleys before attempting to move.
5. Care should be taken not to over tension the net as this can potentially cause each end of a freestanding tennis post to lift and render the posts unstable.
6. We recommend that the net tension is slackened off when the posts are not in use.
7. We recommend the net winder handle be removed if the posts are left unsupervised.

### Netball

1. Freestanding posts must be laid down and stored in a secure covered location when not in use.
2. Freestanding posts must only be wheeled in a pushing motion from the top of the post.

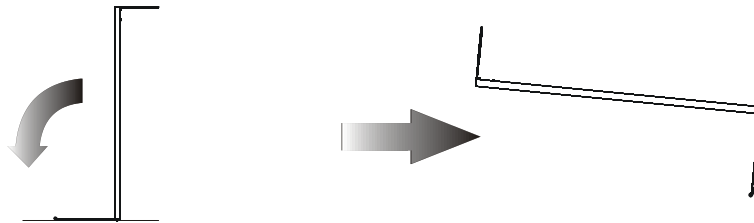

### Basketball

1. Due to the size and weight of the uprights, mechanical lifting equipment must be used when installing or assembling posts.
2. Ground sockets require a minimum 1m cube of concrete.
3. Cantilever arms can only be height adjusted before installation.
4. Slam dunk rings must not be used with standard wooden boards and fixing.

### Shelters

1. Aluminium team shelters are designed to be permanently fixed to an appropriate prepared surface.
2. Correct amount of fixings should be used dependent on the size of the shelter.
3. When moving shelters, the correct number of competent persons are required (please refer to the Manual Handling guidelines).
4. Shelters should never be left unsecured.

### Pitch Dividers

1. Pitch Divider Systems are designed to have wire as a permanent fixture and this should not be removed on a regular basis.
2. If wire is required to be taken down, release the pressure on the wire, detach from anchor post, coil and tie it off, then store the wire in pouch with the netting.
3. Pitch divider netting is retractable and should be stored in a storage pouch.
4. The netting must be retracted using a 'pull and draw' system. This is achieved by standing at the storage end of the system and by slowly pulling the net inwards until all the netting has been gathered. Do not walk with it from one end to another as this will cause the netting to become entangled and put excess stress on the clips used to suspend the netting.

# Goal Post Safety

General Operation & Maintenance Recommendations  
for Sports Ground Equipment



## GUIDELINES FOR SPECIFIC SPORTS (continued):

### Rugby

1. Ensure the correct amount of concrete is in place for the sockets before assembling posts. Please refer to your product assembly instructions to find the amount of concrete required.
2. Allow a minimum of 3 people to allow safe erection of all Rugby posts.
3. Always erect one upright at a time and ensure the crossbar is removed before taking the posts down.
4. Hinged Rugby Posts can be used with a Rugby Lifter and small tractor to ensure quick and safe erection. This allows for maintenance to be easily carried out mid-season if required.
5. Socketed Rugby Posts are erected by inserting them into a socket in the ground which has been securely cemented in place. Due to the nature of Socketed Rugby Posts, they are more difficult to put up and take down than Hinged Posts, therefore, maintenance is best carried out at the end of season.
6. If possible, remove and store posts between matches, but posts are normally left erected for the season.
7. Rugby posts are best and most easily moved with the aid of the Rugby Storage Trolley. The trolley is designed to transport and store all the components required for half a set of posts. This means two trolleys will be required for one full set of posts.

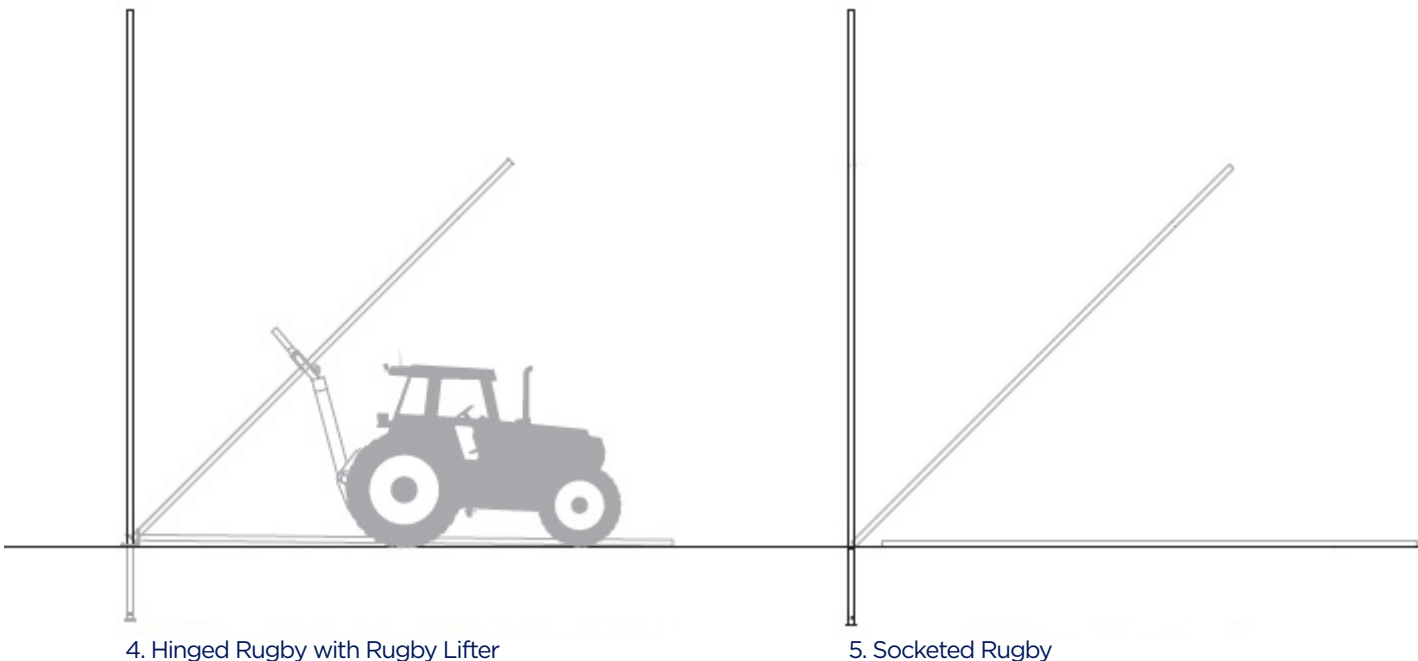

# Goal Post Safety

General Operation & Maintenance Recommendations  
for Sports Ground Equipment



## ANCHORAGE

### Background

In the UK, standards for Goal posts and nets for a variety of sports are set by The Comité de Européan Normalisation which has been in existence since 1989. Other standards have also been set in more recent times by the BSI, specifically for junior, mini, small-sided football and Futsal. Harrod Sport have been representatives on the CEN Committee since 1989, the F.A. Guidelines Committee in 2003 and the BS 8462/8461 Committee in 2005.

### Purpose of CEN

To normalise and raise standards for goal posts throughout the European Community. A committee whose aim is to ensure all equipment is manufactured to the highest standard, and to create awareness of the highest level of responsibility bestowed upon the authorities responsible for the equipment and its use.

### Implications

Providers of sports equipment have a responsibility to supply equipment that is fit for purpose and above all safe to use at all times. Equipment that conforms to BSEN and BS standards has to be independently tested for both 'strength' and 'stability' by a registered testing house and manufacturers are obliged to produce copies of these certificates on demand.



At Harrod Sport we have long since identified the need for 'bullet proof' goals and have developed a unique range of integrally-weighted goals. These goals are safe to use at all times, require no further anchorage and have been widely acknowledged at the SAPCA and Sports College. Conferences as the safest metal goal available in the market place today. The continuing F.A. campaign highlights the responsibilities of pitch providers to ensure they only use goals that conform, and we cannot emphasise strongly enough that end users have the ultimate accountability.

## Official Goal Sizes

Type of Goal	Internal Sizes (mm)	European Standard	Amount of ANC-005* Required
Senior (Full Size)	7320 x 2440	BS EN 748 (if over 42kg) BS EN 16579 (if under 42kg)	6 per goal See product instructions
Youth Football	6440 x 2130	BS EN 16579	See product instructions
9v9	4880 x 2130	BS EN 16579	See product instructions
Mini Soccer	3660 x 1830	BS EN 16579	See product instructions
5-a-side	4880 x 1220 660 x 1220 2440 x 1220	BS EN 16579	See product instructions
Futsal	3000 x 2000 x 2000	BS EN 16579	See product instructions
Hockey	3660 x 2130	BS EN 750	10 per goal

**Anchorage:** To achieve the above stability test, goals (in the case of socketed type) must be installed with the correct amount of concrete around the socket, or in the case of freestanding goals, be anchored in the correct manner. Full details of Harrod Sport anchorage systems are available at [www.harrodsport.com](http://www.harrodsport.com)



Tel: 01502 583515

Email: [sales@harrod.uk.com](mailto:sales@harrod.uk.com)

Harrod UK, Pinbush Rd, Lowestoft

Suffolk NR33 7NL



[@HarrodSport](#)



[HarrodSport](#)



[HarrodSport](#)

**[harrodsport.com](http://harrodsport.com)**